

Machine Dimensions

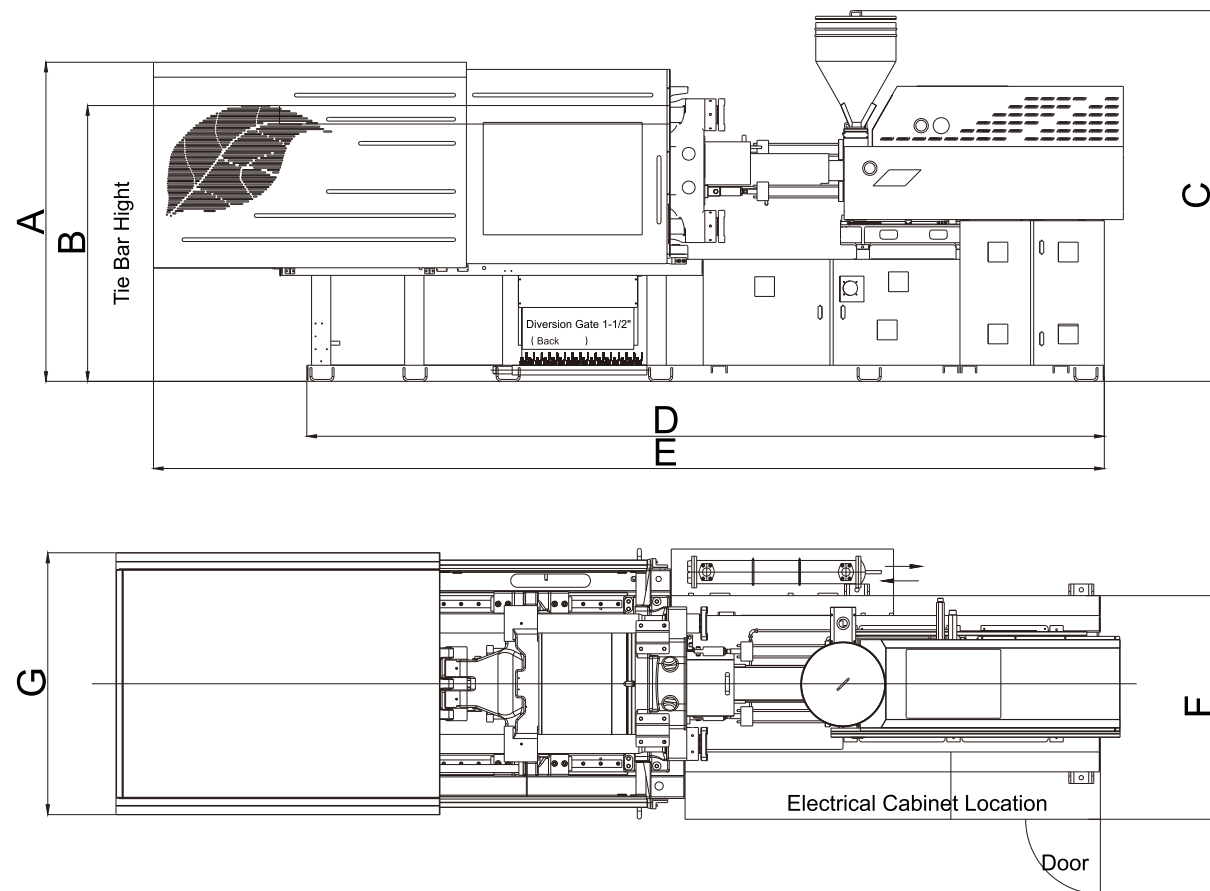

MODEL	A	B	C	D	E	F	G
233SEc	1797	1642	2248	4710	5654	1710	1485
293SEc	1879	1717	2308	4970	6060	1540	1573
353SEc	1962	1766	2280	6222	7023	1934	1880
423SEc	2011	1805	2322	6580	7431	2490	1980
613SEc	2192	1966	2414	7551	8563	2614	2270

Remark: C-hopper height for reference only



SEc Series Servo Energy Saving
 Thin-wall High Speed Special Injection Moulding Machine (233-613Ton)

ЕВРОПОЛИМЕР ТРЕЙДИНГ

Адрес: Ростов-на-Дону, ул. Вавилова 59

Тел: +7 (863) 309-03-88

Сайт: <https://tpa-ept.ru/>

Email: tpa@ep-group.ru



Structural Innovation

The precision and energy saving servo-driven system satisfies high-speed production.

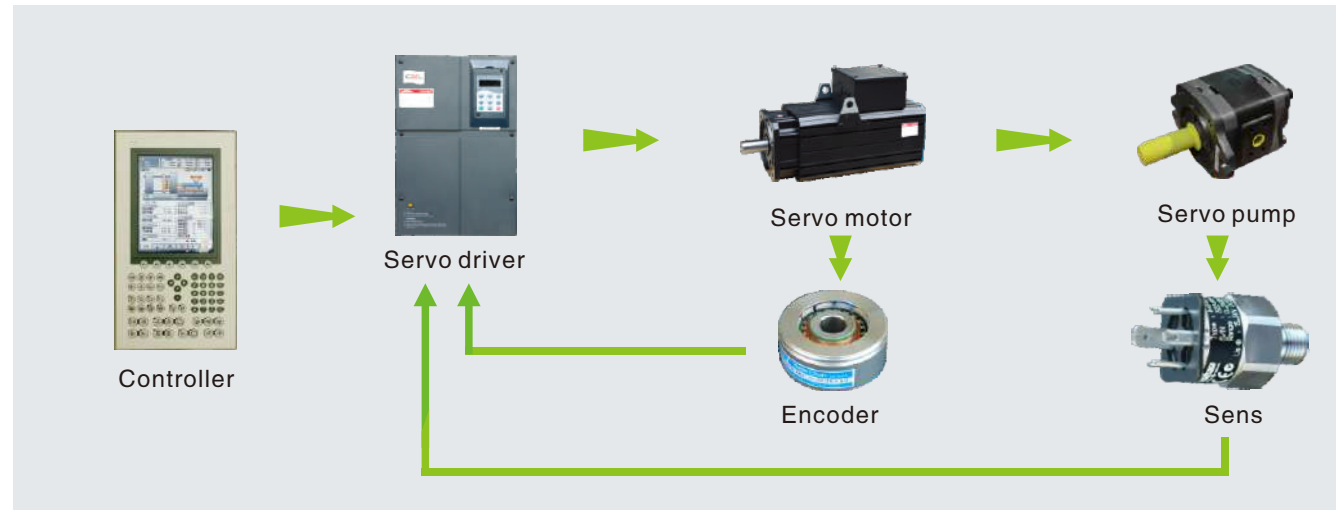

Stresses are evenly distributed through the platens and the center of the mould, high platen-parallelism to minimize flashes and reduce the demand for clamping force.

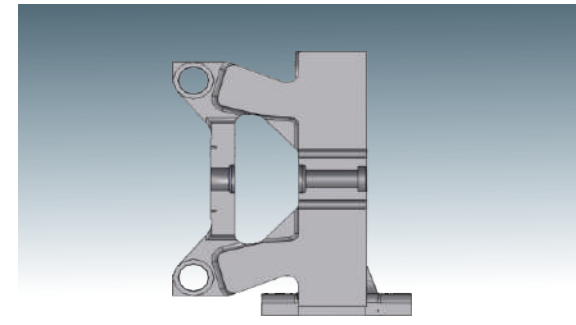

Stress-reducing mould platen designs to help maintaining platen-parallelism effectively and delivering products with even thickness.

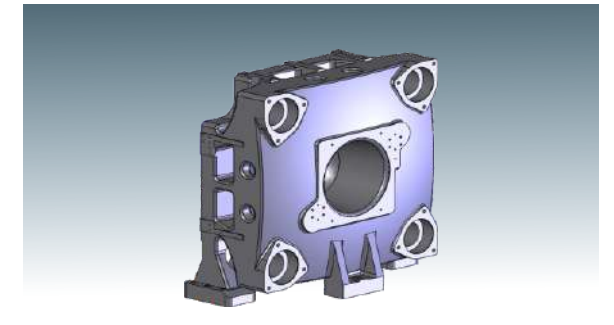

Austrian made, B&R professional control system designed for injection moulding machine, equipped with high-speed control program, 10.4-inch colour screen and network data interface. Providing excellent HMI user-friendliness.



Optimised mould platen reduces deformation and stress. It improves durability to cater to high precision injection moulding.

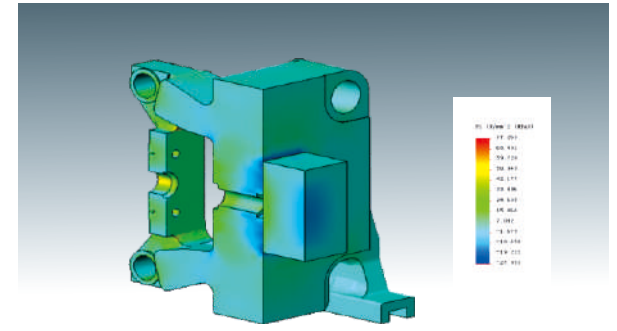

High rigidity clamping structure equipped with linear slide rail and proportional valve is more suitable for high speed system.

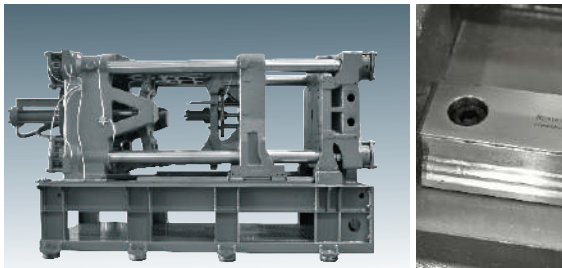

The special stress-relief groove of tie bar is designed to disperse the clamping stress and avoid breaking.

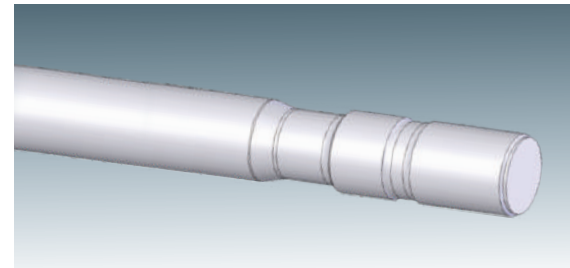

Injection by single cylinder to effectively avoid breaking of injection screw and piston which are commonly seen in the imbalanced double-cylinder injection designs.



The design of the clamping toggle has been optimized to follow high-speed motion curve, and reduce stress for mould open/close which avoids damaging the toggle.



High-speed and stable hydraulic circuits for mould open/close to achieve very sensitive and low-pressure mould protection. Hydraulic components of renowned brands to ensure high repeatability in mould open/close position accuracy of $\pm 0.15\text{mm}$.



High response servo system is supported by -- High response, low inertia and high KT value special servo motor, 30ms perfect acceleration (0-2000rpm) together with the seamless connection by high response CAN communication servo driver and the special control system.

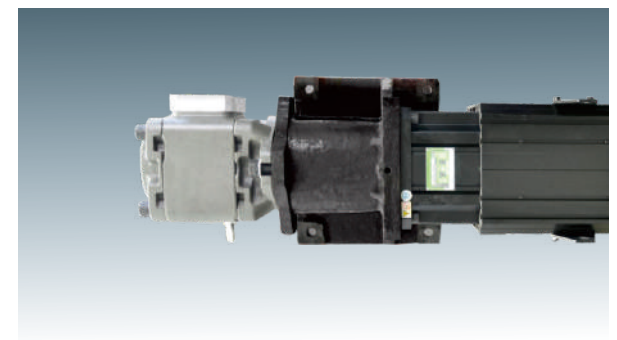



Medical Consumables

The features of injection moulded syringe:

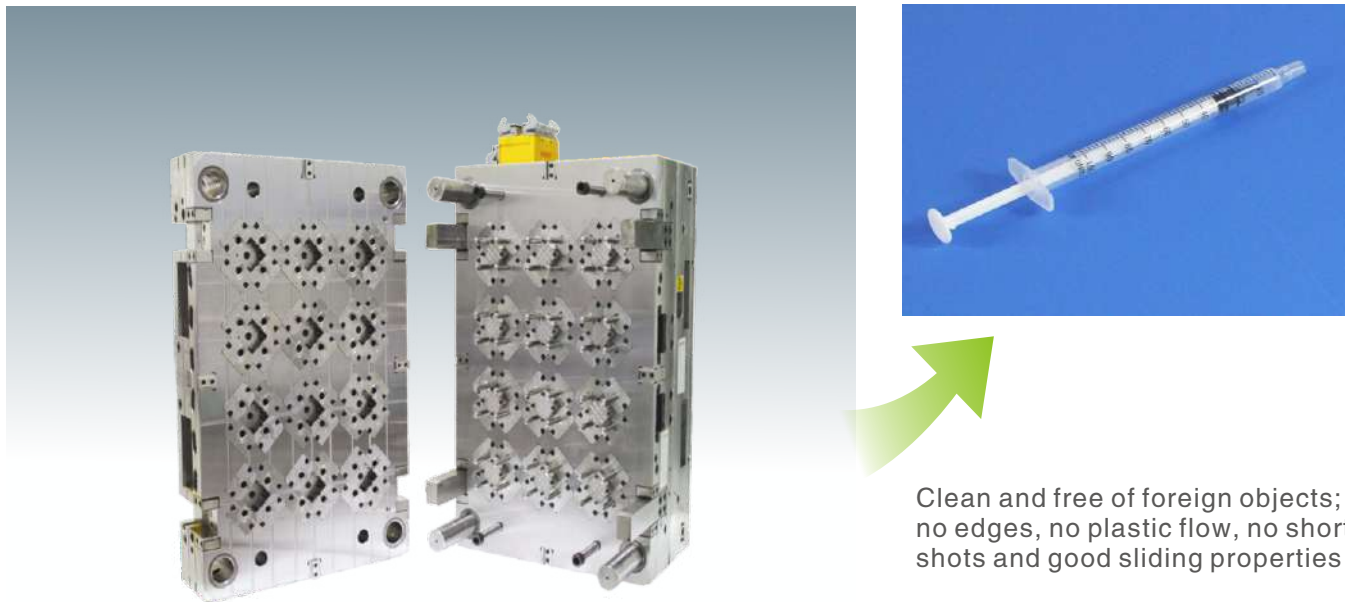

Clean and free of foreign objects; no edges, no plastic flow, no short shots and good sliding properties

Food Packaging

The features of injection moulded food containers

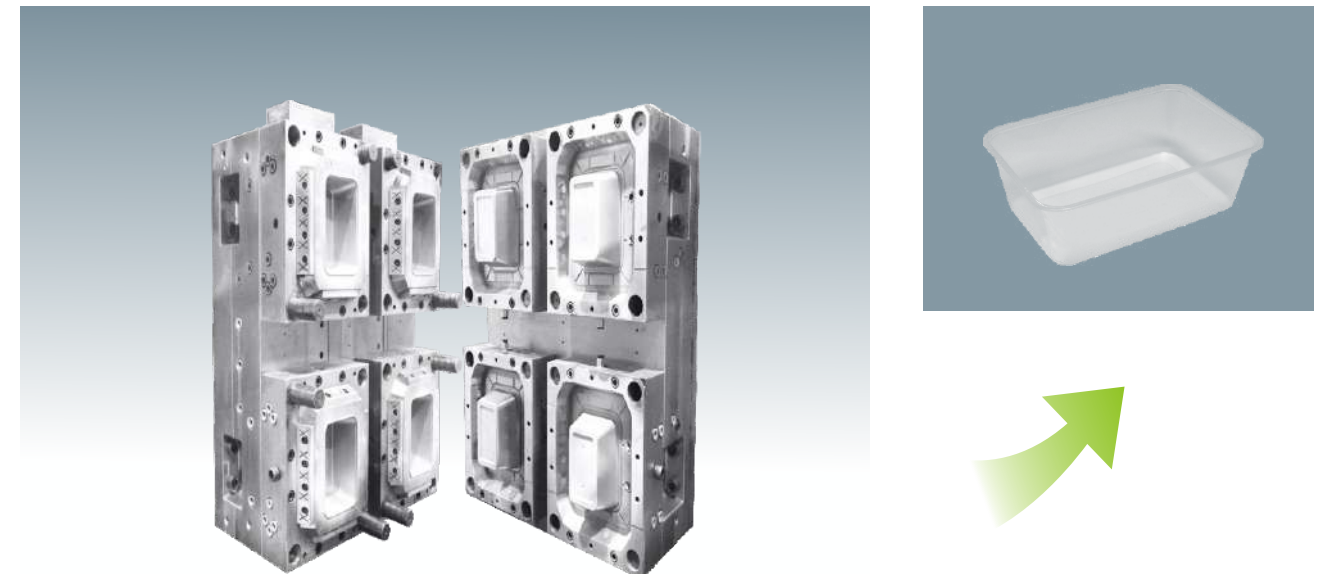

Food container is durable. High pressure resistant and high-loading bearing qualities are achieved by uniform wall thickness, high tensile strength, good sealing and stable chemical properties.

Specification and model of medical consumable

Number	Specification	Cavity Number	Model
①	Straight-mouth single-use barrel	2ml	233SEc
②		5ml	233SEc
③		10ml	233SEc
④		20ml	293SEc
⑤		50ml	353SEc
⑥	Syringe plunger	2ml	233SEc
⑦		5ml	293SEc
⑧		10ml	233SEc
⑨		20ml	293SEc
⑩		50ml	423SEc

Specification and model of food packaging

Specification Number of cavity Model	Round/Square food container						Round/Square lid	
	350ml	500ml	750ml	1000ml	1250ml	1500ml	500ml	1000ml
233SEc	4	4	2	-	1	1		2
293SEc	6	4	2	2	1	1	6	4
353SEc	8	8	6	4	4	4	8	8
423SEc	12	8	8	6	6	4	12	8
613SEc	16	9	9	8	8	6	16	-

*The above is for reference only.





Main Specifications



Item		233SEc	293SEc	353SEc	423SEc	613SEc
Screw diameter	mm	45	50	55	60	65
Theoretical shot volume	cm ³	254	353	523	622	730
Shot weight (PS)	g	232	322	476	566	664
Shot weight (PS)	OZ	8	11.4	16.8	20	23.5
Length/Diameter ratio	L/D	22	22	25	25	23
Injection pressure	MPa	178	176	178	188	160
Injection speed	mm/s	225	300	380	475	500
Injection rate	cm ³ /sec	360	585	900	1345	1645
Injection stroke	mm	160	180	220	220	220
Max. screw speed	rpm	340	320	300	280	280
Plasticizing capacity (PS)	g/s	37.8	47.0	60.5	73.1	87.0
Injection unit force	Ton	5.7	7.2	10.7	10.7	10.7
Carriage stroke	mm	360	390	490	490	530
Clamping force	Ton	233	293	353	423	613
Max. daylight	mm	1070	1145	1300	1400	1600
Clamping stroke	mm	520	545	650	700	850
Distance btwn Tie bars(H x V)	mm	560x520	610x580	680x650	755x715	820x800
Min. mould dimension(H x V)	mm	390X360	420X400	470X450	530X500	575x560
Mould thickness range	mm	250-550	280-600	280-650	300-700	350-750
Ejector force	Ton	6.7	6.7	7.7	11.1	16.1
Ejector stroke	mm	120	120	140	150	200
No. of ejector pins	unit	5	9	13	13	13
Max. motor power	kW	34	51	80	128.7	131
System pressure	MPa	17.5	17.5	17.5	17.5	17.5
No. of heater zones	unit	5+1	5+1	5+1	5+1	5+1
Heater input power	kW	18	19.5	27.5	30	37.1
Ultimate capacity	kW	53	71.5	108.5	159.7	169
Current	A	81	109	165	243	257
Machine net weight	Ton	8.8	11	15.2	19	25
Oil filling capacity	L	450	460	800	1000	1300

Note:with* as a standard parameter

■ We are always working on improvement and reserve the right to change design and specifications without prior notice

Platen/Nozzle Dimensions

