

Our offices and agents



 CPMIA
Energy Saving Award

WELLTEC

1000-4000JSe II

Ultra Large-sized Servo-driven
Two-platen Injection Moulding Machine



ЕВРОПОЛИМЕР ТРЕЙДИНГ

Адрес: Ростов-на-Дону, ул. Вавилова 59

Тел: +7 (863) 309-03-88

Сайт: <https://tpa-ep.ru/>

Email: tpa@ep-group.ru

Ultra-short moulding cycle

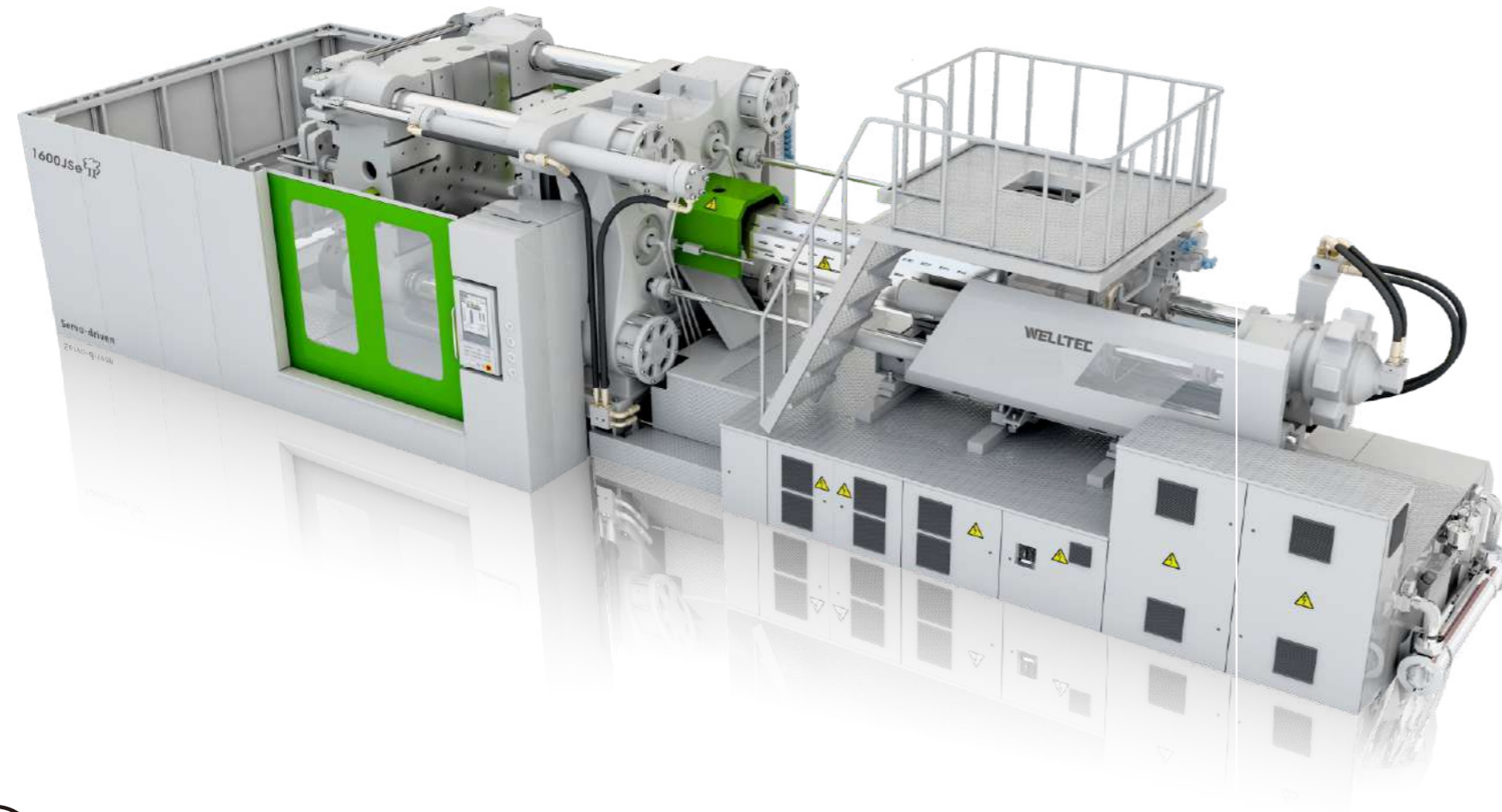

We know you want to shorten the cycle time.
We also know you expect a very high reproducibility.
To achieve a significant increase in productivity,
we are always your right partner.



Patented technologies
Advanced clamping toggle structure



Energy saving and environmental friendly
Energy saving by more than 50% on average



High repeatability
Product weight repeatability of less than 0.3%



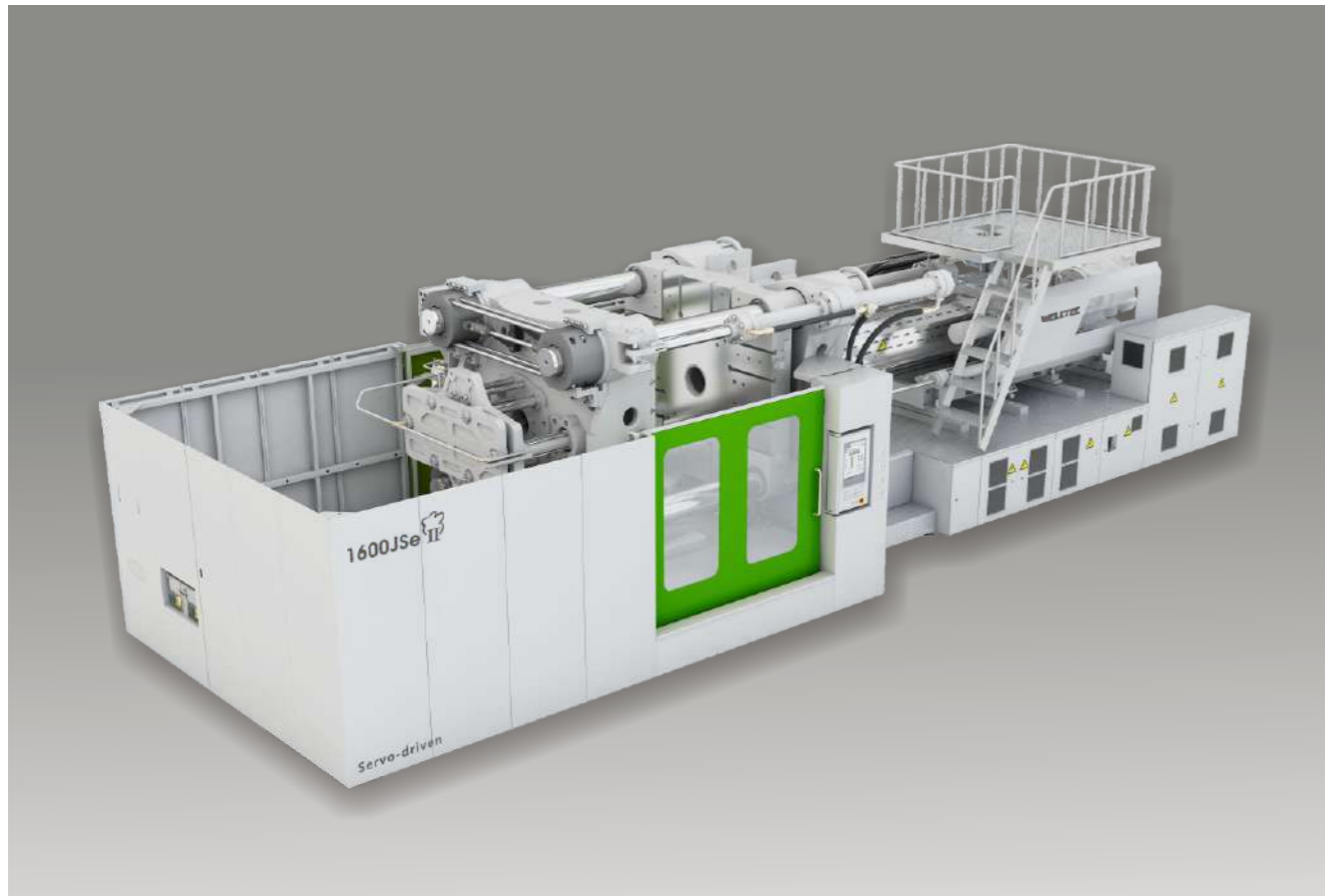

Energy saving and environmental friendly

Driven by revolutionary intelligent energy saving servo system, it has been rated Grade 1 energy saving efficiency as per the National Standards. Saving more than 50% electricity compared to traditional fixed pump systems.

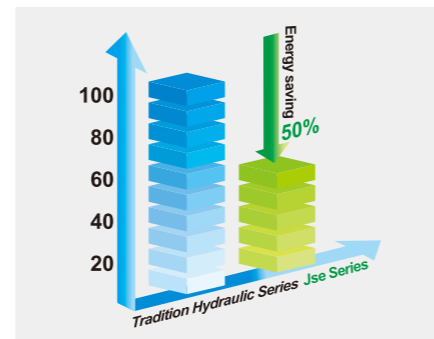

High products weight repeatability

Ultimate product weight repeatability of less than 0.3%



State-of-art injection unit designs

- Compact structure and high-rigidity injection unit.
- Modular designs to allow mix-and-match with unparalleled flexibility between injection and clamping units for catering wide range of injection shot weights and moulding needs. Short machine production lead time is realised.
- Double cylinder injection carriage and barrel support to avoid vertical positional shifts and enable easy adjustments. Stable injection unit movements and accurate volumetric injection controls to make sure the parts are precisely moulded. High-strength guide rail to reduce deformation of the injection unit. Maintenance work at the screw and barrel is serviceman-friendly due to the swiveling injection design.

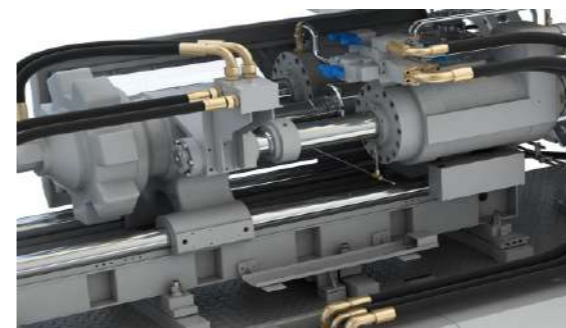
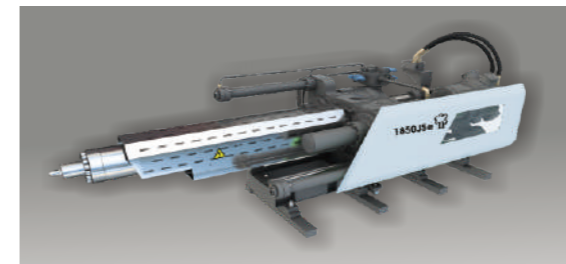

High-response proportional valve

The hydraulic system uses a high-response proportional valve to improve the accuracy and stability of mould open/close. This also shortens the brake response time.



B&R control system

- Austrian made, advanced professional control system for injection moulding machine from B&R Automation
- 15" TFT colour LCD display
- Log for parameter changes, historical logs are available to see what, when and who did the changes for troubleshooting and maintenance conveniences
- QC data logger is available to assist in statistical process control and machine fine-tuning
- Multi-lingual HMI
- The whole control system adopts full digital control and the CPU has an extremely short response time. With optimizations to combine and switching among various hydraulic power packs, the speed and pressure follow a well-tuned linearity curve. It enables smooth movements, accurate positioning and high repeatability of product weight and dimension
- **iSee** Remote monitoring software enables the operator to see the exact the same screen as if physically present at the machine, where one can check and monitor real-time machine working status and get QC reports from anywhere at anytime

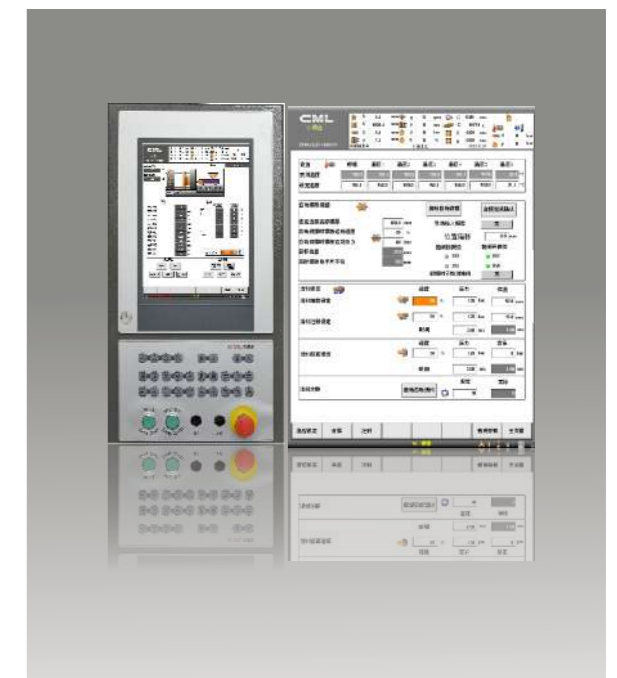

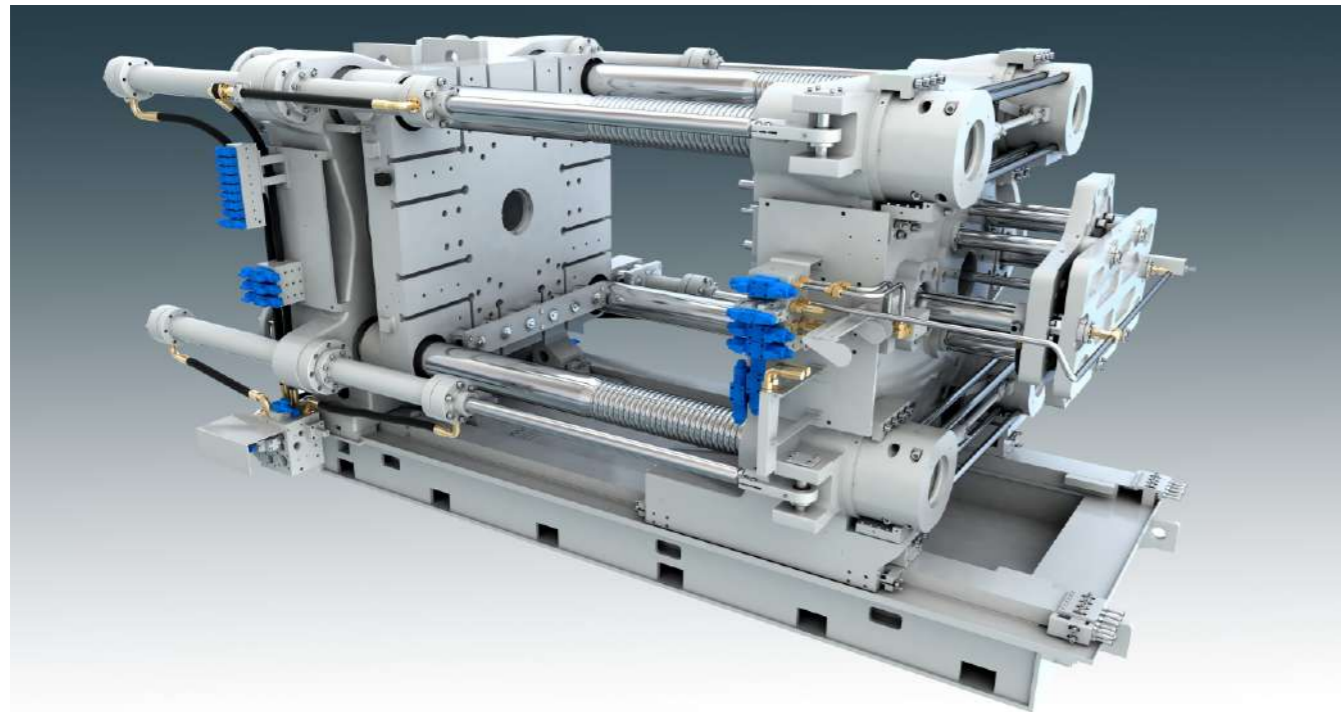

Six cylinders direct clamping structure

Mould open/close and high pressure clamping are done by two groups of mechanical structures. Machine motion stability is greatly enhanced. Six cylinders aligned hexagonally behind the moving platen act directly on the mould mounting surface, which contributes to less mould deformation and better mould protections, thus minimizing product defective rates.

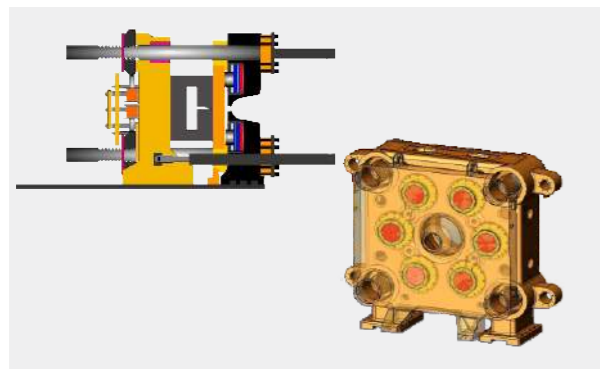

Patented design

Patented design (Patent No. : ZL 200420083893.2)
High pressured direct hydraulic clamping by six hexagonally distributed cylinders.



Accurate tie-bars locking with zero shocks

Locking nuts are linked by connecting rods. They are highly synchronized and moving swiftly. Buffering mechanism is equipped to ensure low noise and zero shocks.



Retractable tie bar (Option)

Side entry of the mould to the clamping unit is possible. It is especially useful and essential for the production floor with low ceiling.

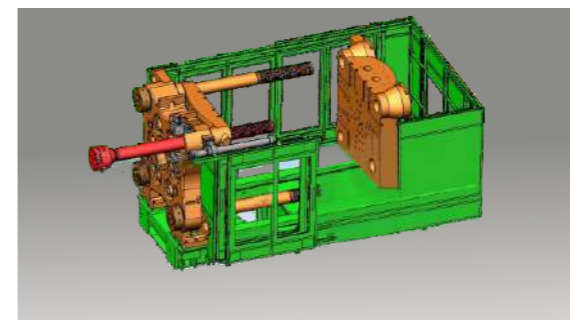

Super-short cycle time

Comparing to traditional toggle machine models, the dry cycle time is shortened by 40%.

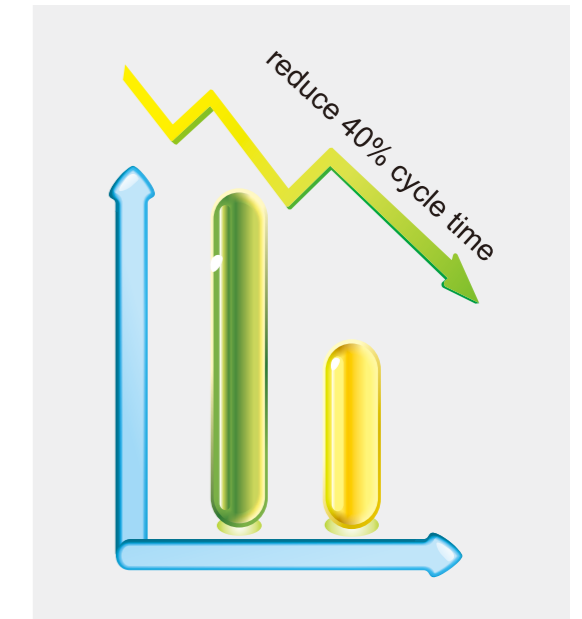

High precision and stable clamping force

High precision clamping force stability, repeatability, excellent-tuned linearity curve against the system pressure, result in strengthening mould protection and minimizing product weight variations.

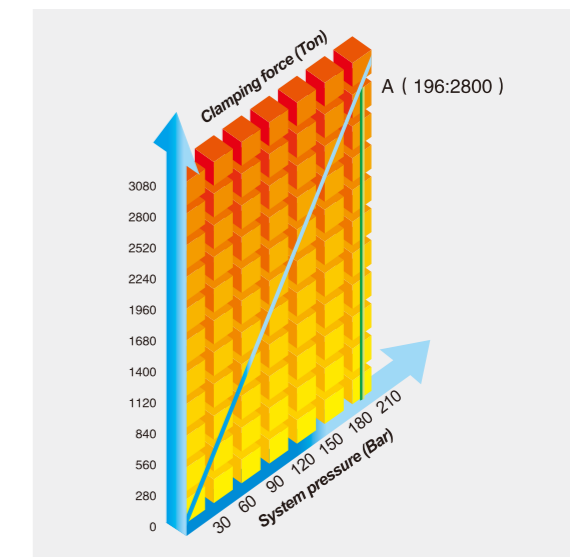

Standard ● Optional ○

Standard and Optional Features

Injection Unit		
Injection stroke controlled by transducer	●	
Proximity sensor for carriage	●	
Single-flight screw + mixing head	●	
Regenerative circuit on injection	●	
Nozzle protrusion 100mm	●	
Barrel protection cover	●	
Nozzle protection cover	●	
Diagonal layout of carriage cylinders	●	
Anti-drooling function	●	
Automatic detection of injection failure	●	
Screw cold start prevention	●	
Auto purging function	●	
Heater on/off switch	●	
Powered swivel injection unit	●	
Nozzle centre adjustment device	●	
Cooling water for feeding throat	●	
10 stages closed loop injection speed control	●	
10 stages closed loop hold pressure control	●	
5 stages closed loop metering control	●	
5 stages closed loop back pressure control	●	
Centralised manual grease lubrication	●	
Reduced / Enlarged ONE STEP injection unit		○
Movable hopper		○
Extended nozzle		○
Spring-loaded nozzle		○
Hydraulic / Pneumatic shut-off nozzle		○
Material loading platform		○
Linear transducer for injection carriage		○
Upgrade varieties of screw and barrels for engineering/ recycled/ glass fiber contented resins		○
Electric plasticising		○
Clamping Unit		
Patented clamping mechanism	●	
Clamping stroke controlled by contactless linear transducer	●	
Ejector stroke controlled by linear transducer	●	
Auto-mould height adjustment	●	
Automatic lubrication system	●	
Mould protection function	●	
Ejector modes selection (Maximum 9 ejector rods)	●	
T slot mould platen	●	
Moulding area safety pedal (1200- 4000JSeII)	●	
4 stages clamping speed, pressure adjustment	●	
4 stages opening speed, pressure adjustment	●	
2 stages ejector forward speed, pressure adjustment	●	
2 stages ejector backward speed, pressure adjustment	●	
Increase mould thickness range		○
Mechanical safety bar		○
SPI mounting holes platen		○
Quick mould change system (T-slot necessary)		○
Increase ejector force		○
Increase ejector stroke		○

Hydraulic Unit		
High efficiency energy saving servo motor and pump	●	
Paralleled movement of ejector or core pulling during mould open	●	
Hydraulic safety device	●	
Proportional back pressure control for plasticising	●	
Two sets core pulling device at movable platen	●	
Return line filtering device with blockage	●	
Non-return check valve for injection carriage	●	
Hydraulic oil temperature display and alarm	●	
Hydraulic oil level alarm	●	
Lubrication oil level / pressure alarm	●	
Core pulling on fixed / movable platen		○
Hydraulic unscrew device with motor		○
Extra air blast		○
Oil level sensor and alarm		○
Core pulling / Ejector plasticising during mould open		○
Injection accumulator from half to full stroke		○
Proportional direction valves for clamping		○
Hydraulic/ Pneumatic sequential injection		○
Enlarged motor and pump (hydraulic circuit)		○
Solenoid valve for oil cooler to control water flow		○
Control Unit and Electric Components		
Advanced professional control system for IMM from B&R Automation	●	
10.4" TFT LCD screen and touchscreen keyboard	●	
Processor PID temperature control	●	
Barrel temperature hold and pre-heat function	●	
Screw RPM sensor	●	
Closed loop control on injection, holding, plasticising and back pressure	●	
Automatic fault detection and display	●	
Production counter	●	
Emergency button on non- operator side	●	
380V 50Hz voltage	●	
380V 16A socket x 2 sets	●	
380V 32A socket x1 set	●	
Electrical safety interlock	●	
4 levels password protection	●	
SPC quality control	●	
Real time curve display	●	
100 sets of mould data storage (Optional: USB)	●	
Robot interface	●	
Individual power plug of different voltages		○
Voltage stabiliser		○
Solid state relays		○
Power meter		○
Hot runner control		○
Ceramic / Infrared heater bands		○
Lighting inside electric cabinet		○
Electric unscrew (Device interface)		○
Robot interface EUROMAP 12 & 67		○
Air conditioner for electric cabinet		○
Circuit check for heater bands		○
iSee intelligent management system(self-developed software)		○
Others		
Water regulating valves	●	
Safety guard for injection unit	●	
Water flow regulator		○

Specifications

Item	Unit	1000JSeII			1200JSeII			1300JSeII			1400JSeII		
Injection Unit													
Screw diameter	mm	100	110	125	100	110	125	110	125	140	110	125	140
Theoretical shot volume	cm ³	3848	4657	6013	3848	4657	6013	5293	6835	8574	5293	6835	8574
Shot weight (PS)	g	3464	4191	5412	3464	4191	5412	4764	6152	7717	4764	6152	7717
Length/Diameter ratio	L/D	22.3	20.0	17.7	22.3	20.0	17.7	21.6	20.0	18.5	21.6	20.0	18.5
Injection pressure (high pressure and low speed)	MPa	215	178	138	215	178	138	240	185	148	240	185	148
Injection pressure (low pressure and high speed)	MPa	156	129	100	156	129	100	183	142	113	183	142	113
Injection rate (high pressure and low speed)	cm ³ /s	671	812	1048	745	902	1164	804	1038	1302	804	1038	1302
Injection rate (low pressure and high speed)	cm ³ /s	925	1119	1445	1028	1243	1606	1053	1360	1706	1053	1360	1706
Plasticizing capacity (PS)	g/s	93	118	154	93	118	154	108	153	186	108	153	186
Injection stroke	mm	490			490			557			557		
Screw speed	rpm	115			115			105			105		
Injection unit force	Ton	20.0			20.0			20.0			20.0		
Carriage stroke	mm	920			980			1000			1000		
Clamping Unit													
Clamping force	Ton	1000			1200			1300			1400		
Opening force	Ton	106.1			130.7			139.6			149.4		
Opening force	Ton	34.7			42			42.9			43.7		
Max. daylight	mm	2400			2650			2850			3050		
Clamping stroke	mm	1200-1800			1400-2050			1500-2200			1650-2350		
Distance btwn. Tie bars	mm	1210X1060			1310X1160			1410X1260			1460X1360		
Min mould dimension	mm	840x740			910x810			980x880			1020x950		
Mould thickness range	mm	600-1200			600-1250			650-1350			700-1400		
Max mold weight	Ton	15			20			23			27		
Ejector force	Ton	18.2			21.5			25			25		
Ejector stroke	mm	300			350			350			350		
No. of ejector pins	unit	21			21			29			29		
Power Unit													
Dry Cycle (Euromap 6)	S	5.7			6.5			6.8			7.1		
Major motor	kW	88.4			102.6			105.3			105.3		
System pressure	MPa	17.5,22.1			17.5,22.1			17.5,22.6			17.5,23		
No. of heater zones	unit	5+1			5+1			5+1			5+1		
Heater input power	kW	58			58			74			74		
Ultimate capacity	kW	147.4			161.6			180.3			180.3		
Current	A	179.2			196.4			219.2			219.2		
General													
Net weight	Ton	50			60			70			80		
Oil filling capacity	L	1800			1800			2100			2100		

■ We are always working on improvement and reserve the rights to change design and specifications without prior notice

Machine Dimensions

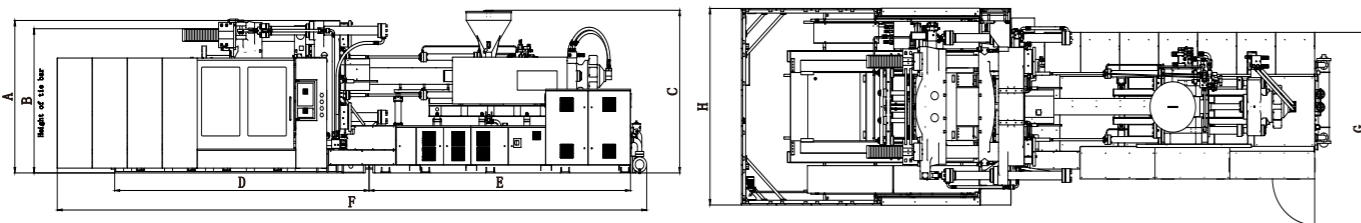

Model	A	B	C	D	E	F	G	H
1000JSeII	2615	2425	2329	4550	4721	10499	3295	3360
1200JSeII	2710	2495	2329	5050	4721	10959	3295	3500
1300JSeII	2795	2620	2412	5100	5565	11818	3505	3570
1400JSeII	2925	2755	2487	5325	5565	12053	3505	3670

Platen/Nozzle Dimensions

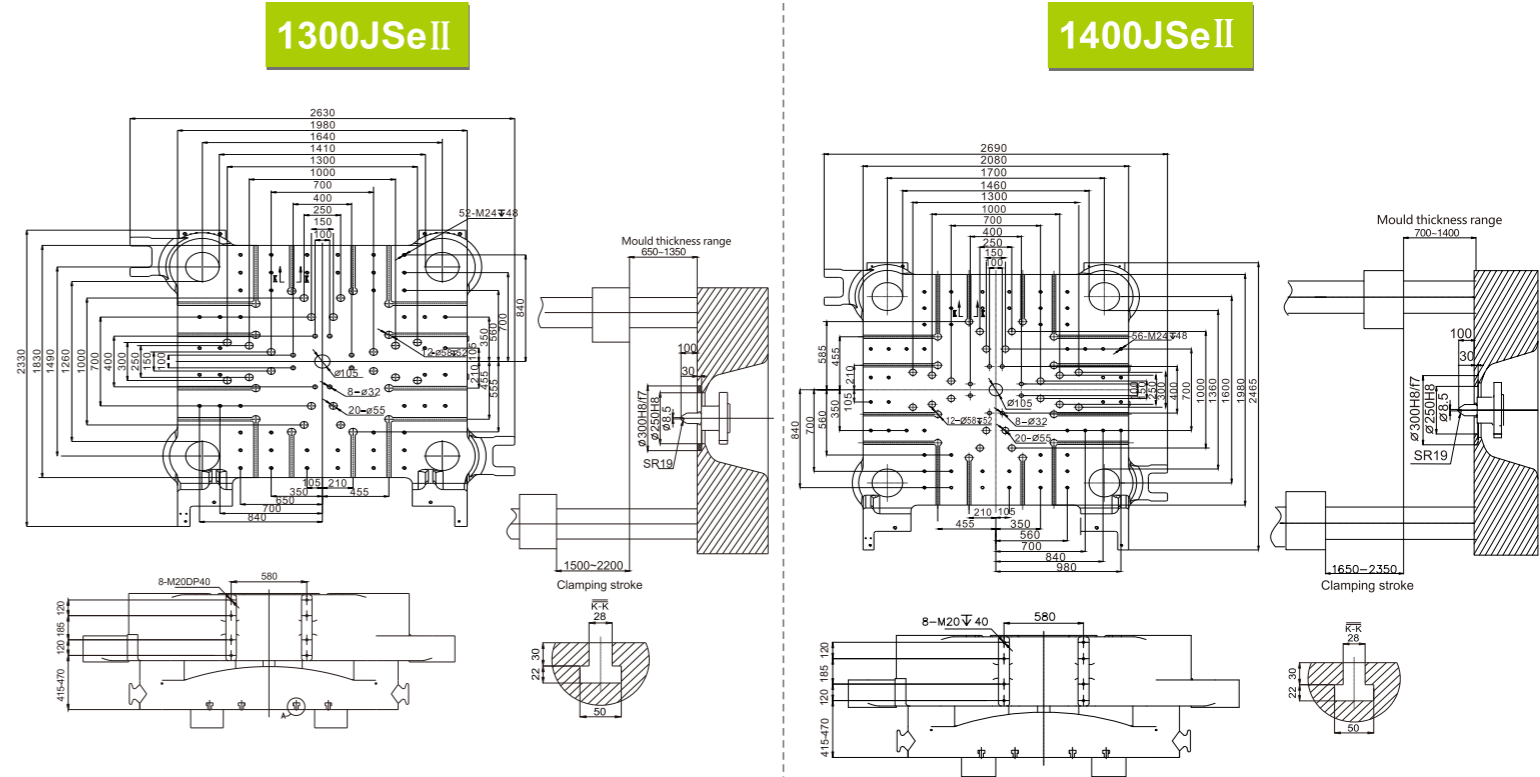
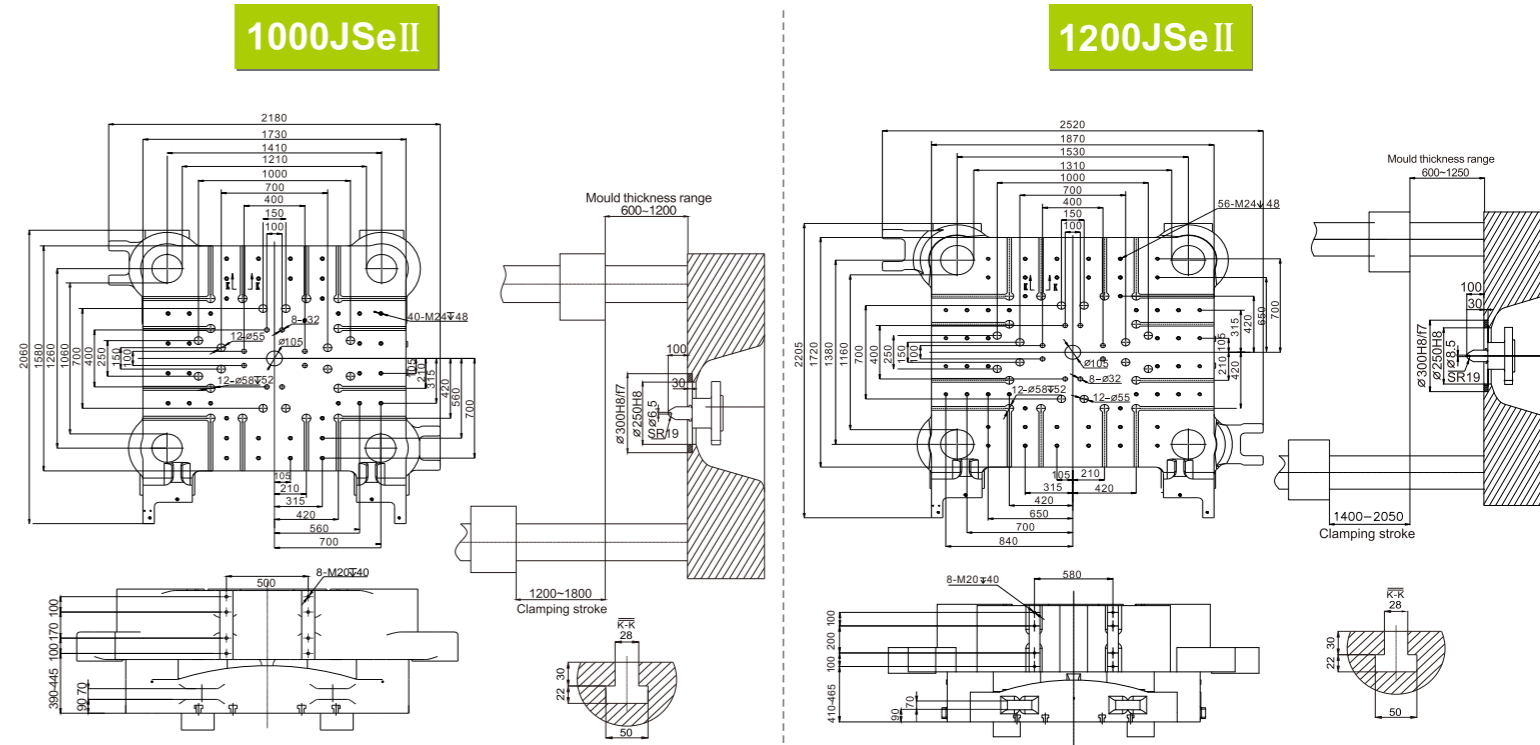

Specifications

Item	Unit	1600JSeII			1850JSeII			2100JSeII			2550JSeII		
Injection Unit													
Screw diameter	mm	125	135	145	135	145	160	135	145	160	140	160	180
Theoretical shot volume	cm ³	7915	9232	10651	9232	10651	12969	9232	10651	12969	11238	14678	18576
Shot weight (PS)	g	7124	8309	9586	8309	9586	11672	8309	9586	11672	10114	13210	16719
Length/Diameter ratio	L/D	23.0	21.1	19.7	21.1	19.7	17.8	21.1	19.7	17.8	24.9	22	19.5
Injection pressure (high pressure and low speed)	MPa	224	192	166	192	166	137	192	166	137	228	174	138
Injection pressure (low pressure and high speed)	MPa	174	149	129	149	129	106	149	129	106	170	130	103
Injection rate (high pressure and low speed)	cm ³ /s	1074	1253	1445	1253	1445	1760	1253	1445	1760	1155	1508	1909
Injection rate (low pressure and high speed)	cm ³ /s	1386	1617	1865	1617	1865	2271	1617	1865	2271	1548	2021	2558
Plasticizing capacity (PS)	g/s	161	199	236	190	226	258	190	226	258	134	189	243
Injection stroke	mm	645			645			645			730		
Screw speed	rpm	110			106			98			106		
Injection unit force	Ton	29.5			29.5			29.5			31.7		
Carriage stroke	mm	1050			1100			1200			1330		
Clamping Unit													
Clamping force	Ton	1600			1850			2100			2550		
Opening force	Ton	166.5			184.6			233.8			269.4		
Opening force	Ton	48.2			49.1			50			53.9		
Max. daylight	mm	3250			3300			3500			3700		
Clamping stroke	mm	1700-2550			1700-2550			1800-2700			1900-2900		
Distance btwn. Tie bars	mm	1560X1410			1660X1560			1850X1600			1900X1700		
Min mould dimension	mm	1090x990			1160x1090			1295X1120			1330X1190		
Mould thickness range	mm	700-1550			750-1600			800-1700			800-1800		
Max mold weight	Ton	33			40			50			60		
Ejector force	Ton	36			36			36			36.3		
Ejector stroke	mm	350			400			400			400		
No. of ejector pins	unit	29			33			25			21		
Power Unit													
Dry Cycle (Euromap 6)	S	7.5			8.6			9.8			11.2		
Major motor	kW	143.5			143.5			143.5			169.8		
System pressure	MPa	17.5, 21.3			17.5, 22.3			17.5, 22			17.5, 21.7		
No. of heater zones	unit	5+1			5+1			5+1			5+1		
Heater input power	kW	92			92			92			122.54		
Ultimate capacity	kW	236.5			236.5			236.5			293.3		
Current	A	287.5			287.5			287.5			356.6		
General													
Net weight	Ton	95			100			120			165		
Oil filling capacity	L	2600			2600			2600			2900		

■ We are always working on improvement and reserve the rights to change design and specifications without prior notice

Machine Dimensions

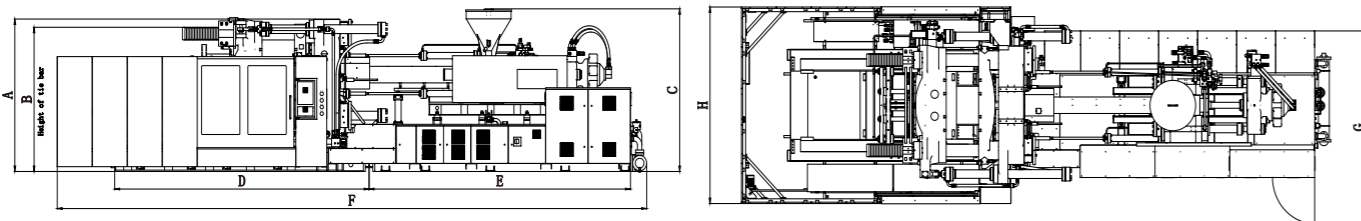

Model	A	B	C	D	E	F	G	H
1600JSeII	3110	2860	3939	5790	5565	12874	4010	3820
1850JSeII	3315	3070	4049	5920	5565	13134	4010	3930
2100JSeII	3370	3125	4074	6140	5565	13344	4010	4130
2550JSeII	3810	3450	4404	6785	6472	14401	4333	4410

Platen/Nozzle Dimensions

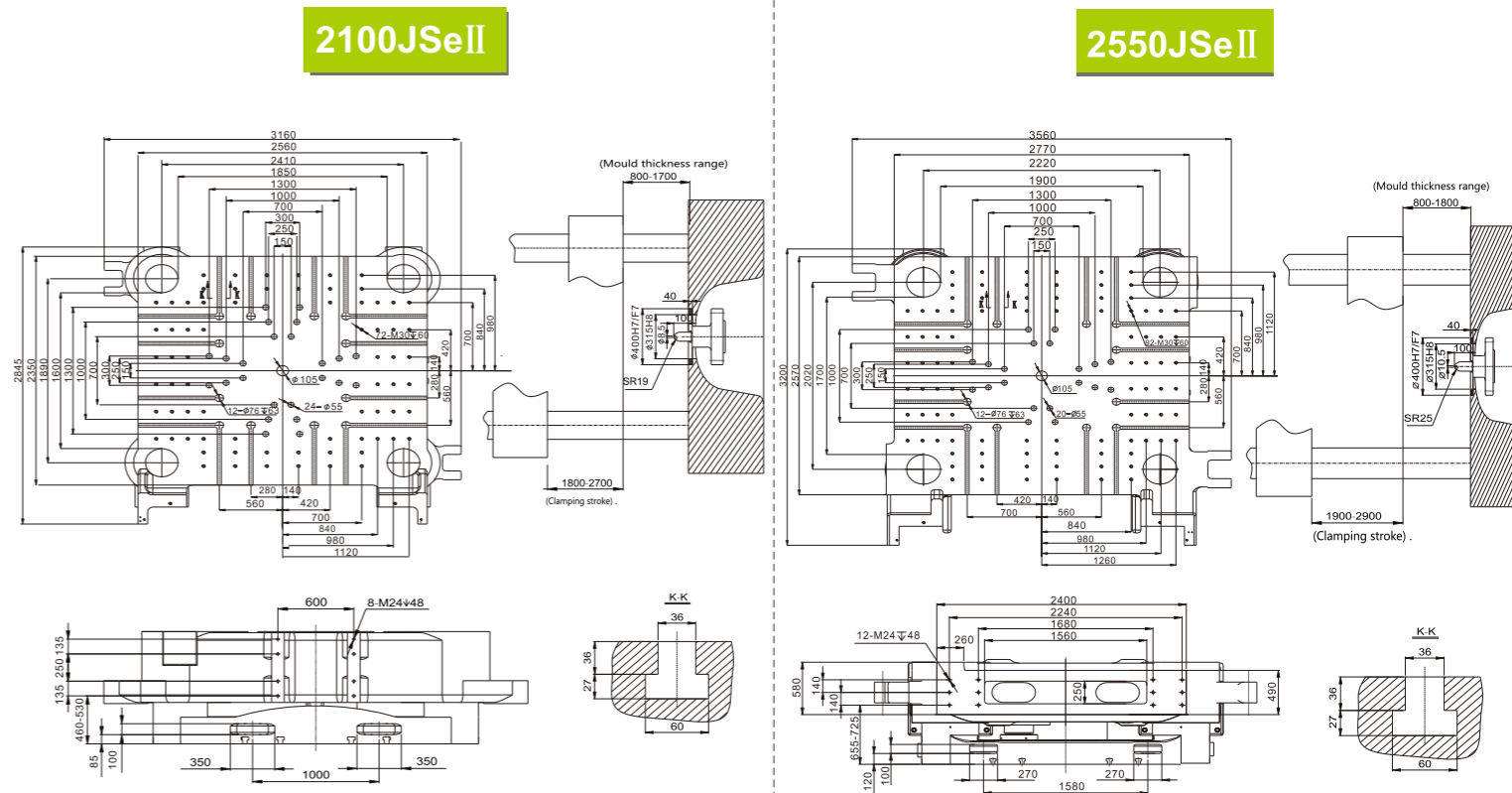
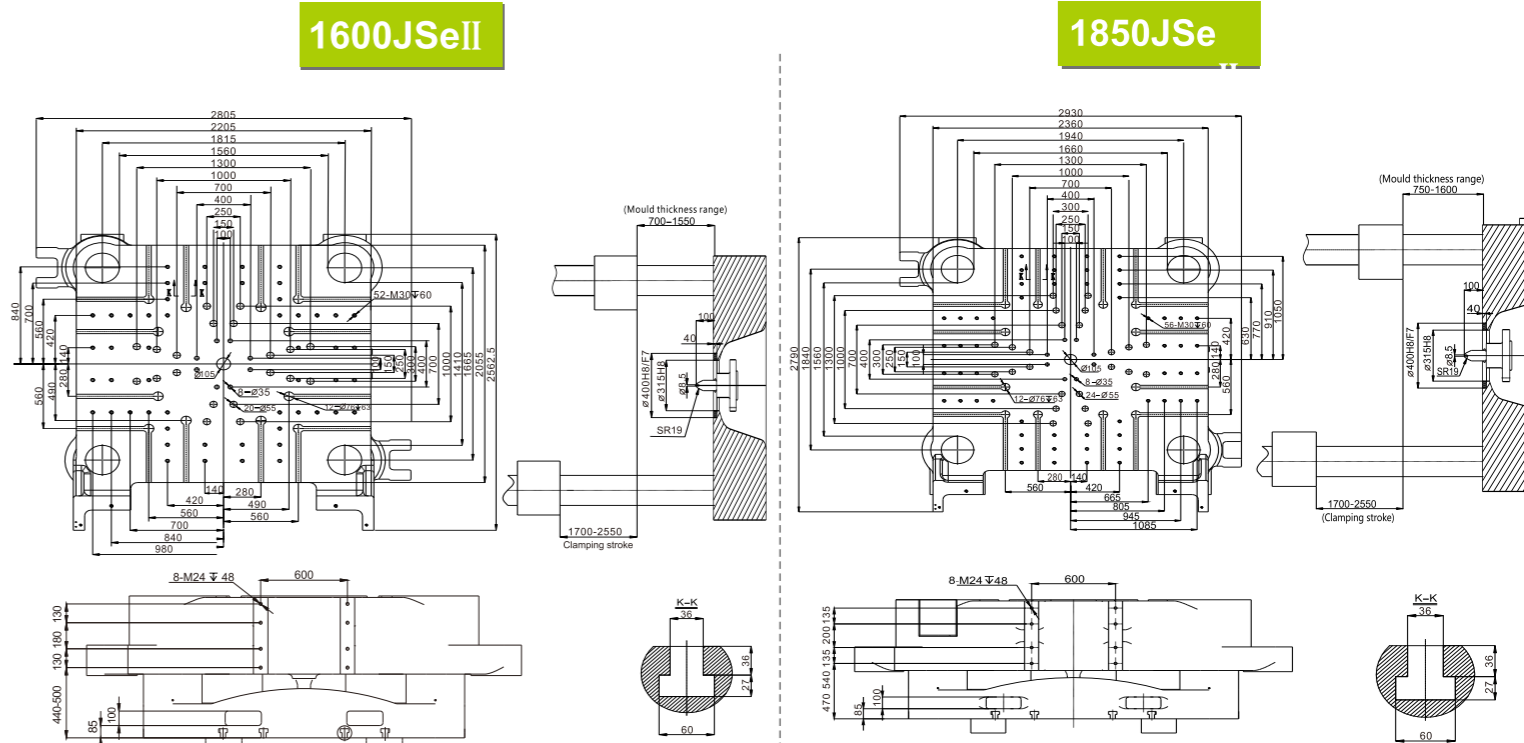

Specifications

Item	Unit	2850JSeII			3350JSeII			4000JSeII		
Injection Unit										
Screw diameter	mm	160	180	200	180	200	225	215	240	260
Theoretical shot volume	cm ³	15281	19340	23876	22902	28274	35785	45381	56775	69021
Shot weight (PS)	g	13753	17406	21489	20612	25447	32206	40843	51097	62119
Length/Diameter ratio	L/D	23.0	20.7	18.4	22.2	20.0	18.2	21.7	21.0	20.0
Injection pressure (high pressure and low speed)	MPa	208	165	133	194	157	124	136	160	161
Injection pressure (low pressure and high speed)	MPa	164	130	105	159	128	101	111	127	129
Injection rate (high pressure and low speed)	cm ³ /s	1262	1597	1972	1823	2251	2849	2601	3118	3580
Injection rate (low pressure and high speed)	cm ³ /s	1602	2028	2503	2225	2748	3477	3175	3905	4478
Plasticizing capacity (PS)	g/s	174	230	281	217	259	329	324	324	330
Injection stroke	mm	760			900			1250		
Screw speed	rpm	60			55			45		
Injection unit force	Ton	31.7			31.7			34		
Carriage stroke	mm	1370			1550			1770		
Clamping Unit										
Clamping force	Ton	2850			3350			4000		
Opening force	Ton	300.3			352.3			432.7		
Opening force	Ton	53.9			70.3			109.9		
Max. daylight	mm	4100			4160			4370		
Clamping stroke	mm	2200-3200			2160-3160			2260-3270		
Distance btwn. Tie bars	mm	2000X1800			2160X1900			2420 x 2020		
Min mould dimension	mm	1400X1260			1510X1330			1690X1410		
Mould thickness range	mm	900~1900			1000~2000			1100~2110		
Max mold weight	Ton	70			75			86		
Ejector force	Ton	53.9			61.8			61.8		
Ejector stroke	mm	450			550			550		
No. of ejector pins	unit	21			29			29		
Power Unit										
Dry Cycle (Euromap 6)	S	12.5			13.2			15.4		
Major motor	kW	169.8			196.5			273.9		
System pressure	MPa	17.5,20			17.5,18.5			17.5,19.5		
No. of heater zones	unit	5+1			6+1			6+1		
Heater input power	kW	134			201.4			228.6		
Ultimate capacity	kW	304.8			398.9			503.5		
Current	A	370.5			484.9			612.0		
General										
Net weight	Ton	198			225			280		
Oil filling capacity	L	2900			3800			6000		

■ We are always working on improvement and reserve the rights to change design and specifications without prior notice

Machine Dimensions

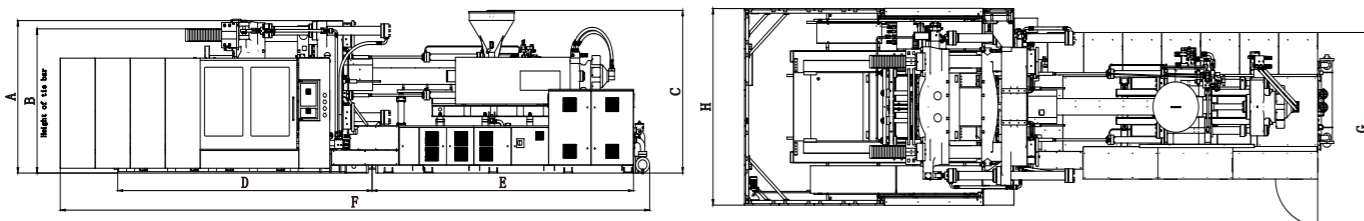

Model	A	B	C	D	E	F	G	H
2850JSeII	3960	3600	4514	7320	6882	15340	4333	4730
3350JSeII	4135	3795	4629	7735	8207	16966	4333	4730
4000JSeII	4475	4375	4185	7770	10702	19441	4306	5242

Platen/Nozzle Dimensions

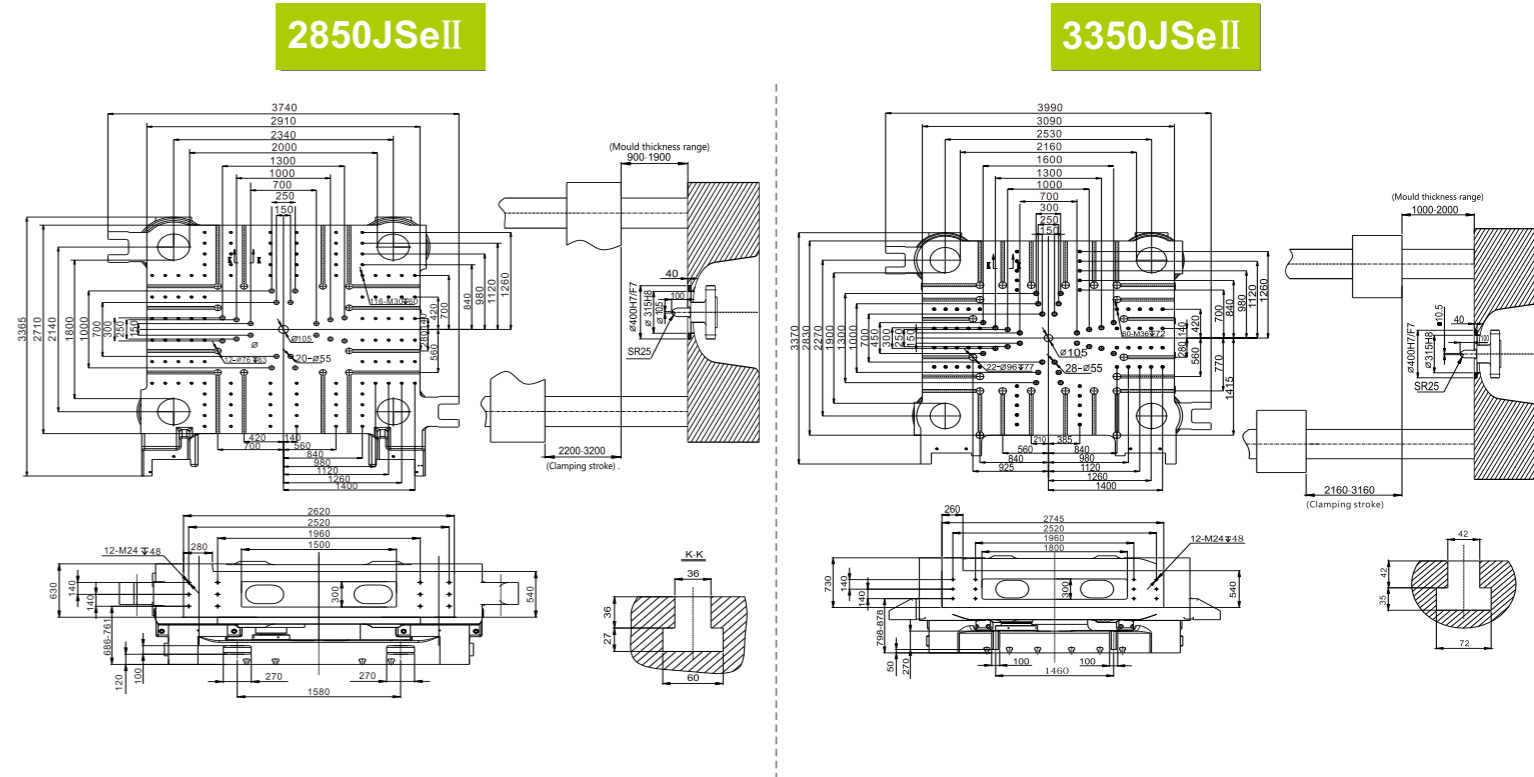

4000JSeII

